



YJG220G06AR

RECOMMEND
[YJG210G06AR](#)
FOR NEW DESIGN

N-Channel Enhancement Mode Field Effect Transistor

Product Summary

V_{DS}

60V



YJG220G06AR

RECOMMEND
[YJG210G06AR](#)
FOR NEW DESIGN

Electrical Characteristics ($T_J=25$ unless otherwise noted)

Parameter	Symbol	Conditions	Min	Typ	Max	Units
Static Parameter						
Drain-Source Breakdown Voltage	BV_{DSS}	$V_{GS}=0V, I_D=250\mu A$	60	-	-	V



Typical Electrical and Thermal Characteristics Diagrams

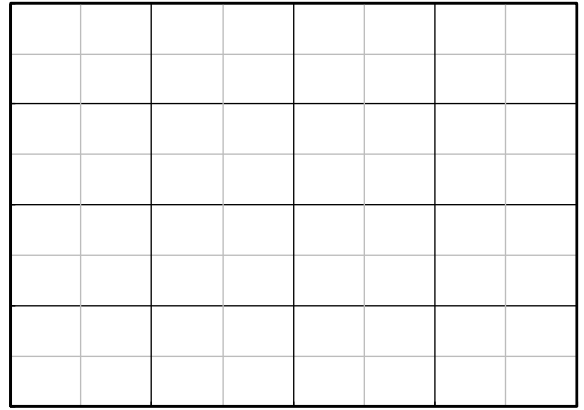
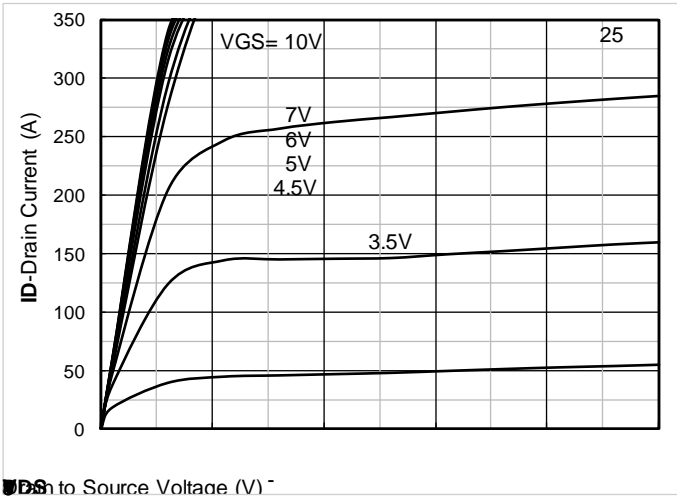

Figure

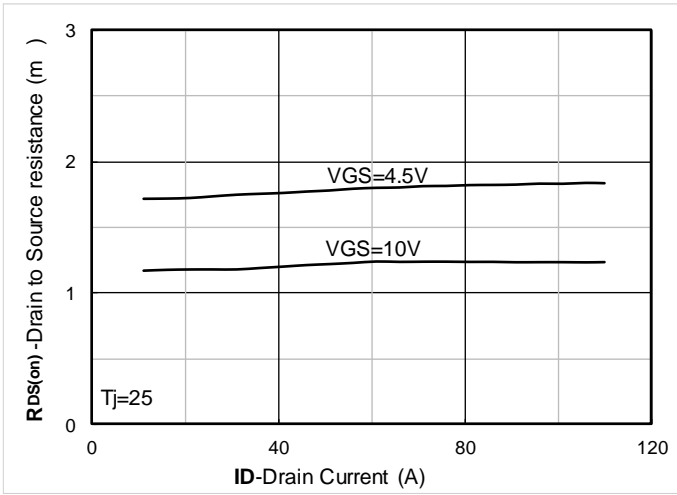

Figure 7. $R_{DS(on)}$ vs Drain Current

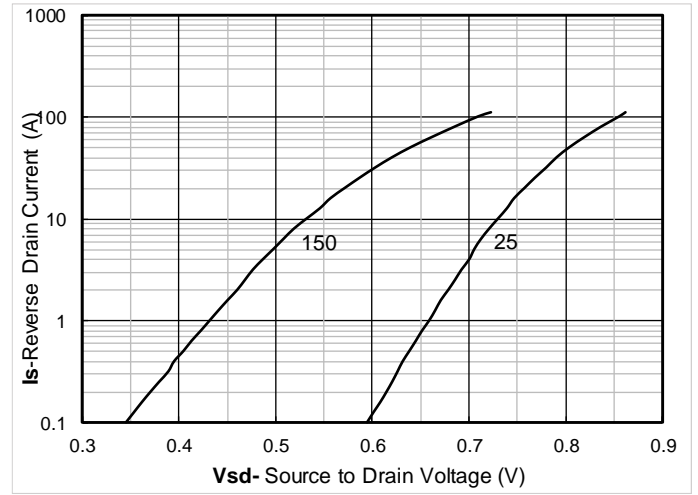

Figure 8. Forward characteristics of reverse diode



Figure 9. Normalized breakdown voltage

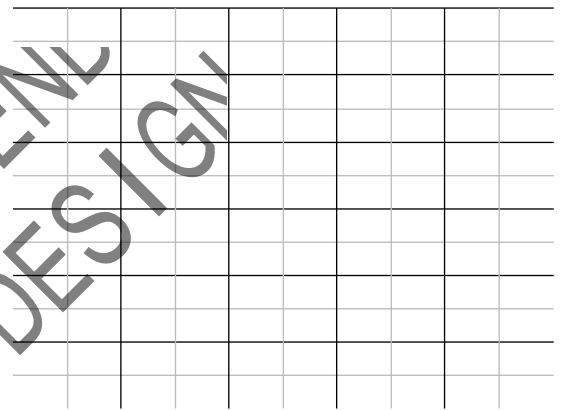

Figure 10. Normalized Threshold voltage

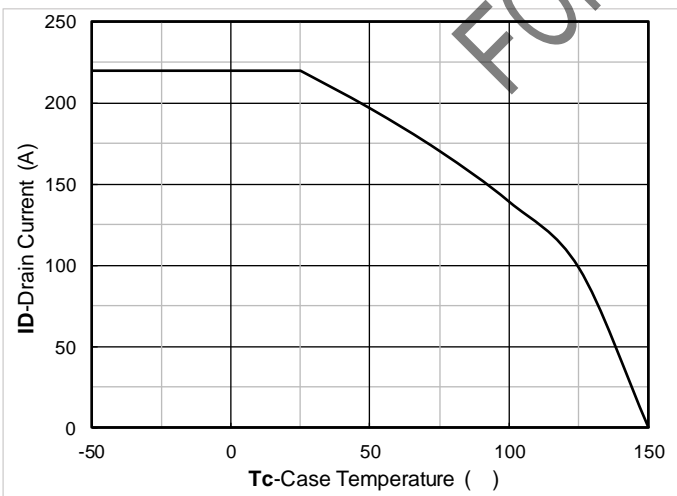

Figure 11. Current dissipation

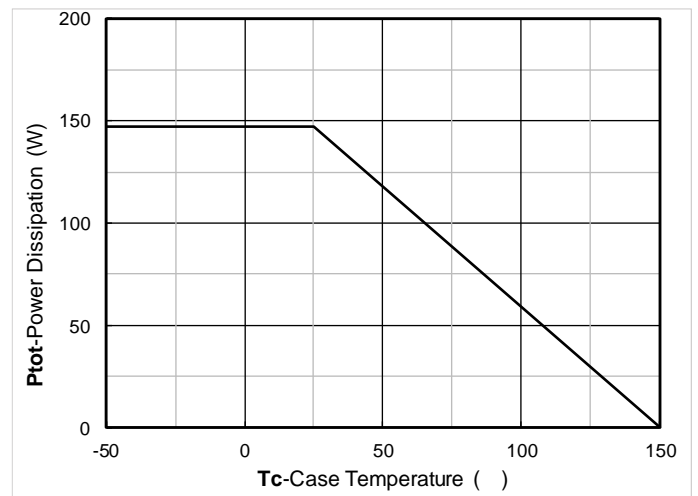

Figure 12. Power dissipation

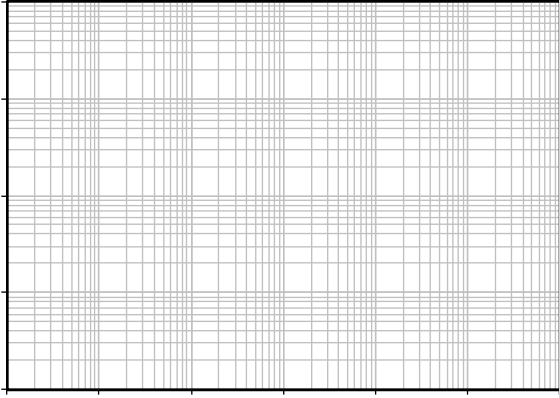

Figure 13. Maximum Transient Thermal Impedance

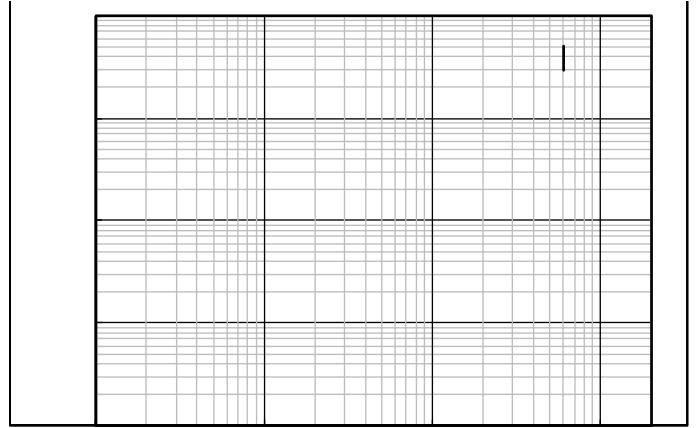

Figure 14. Safe Operation Area

Test Circuits & Waveforms

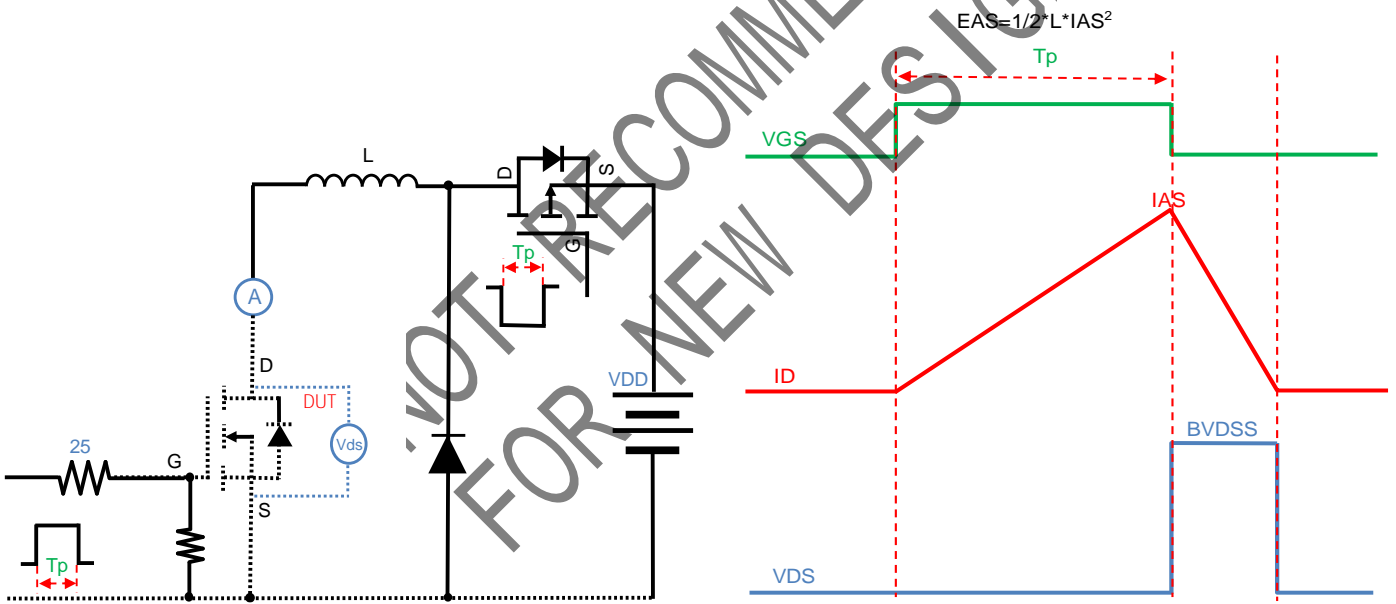

Figure A. Unclamped Inductive Switching (UIS) Test Circuit & Waveform

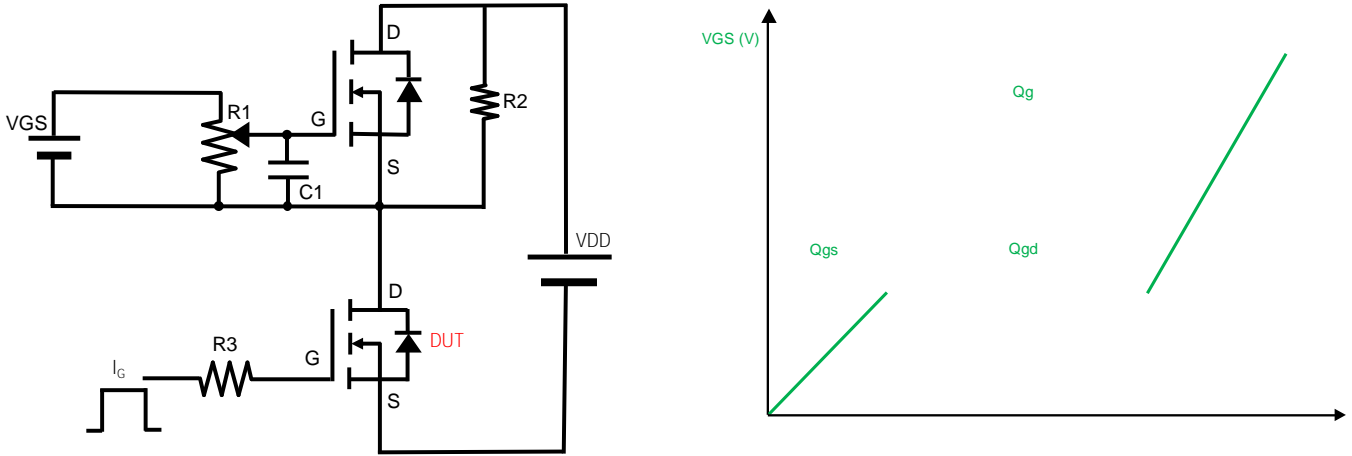

Figure B. Gate Charge Test Circuit & Waveform

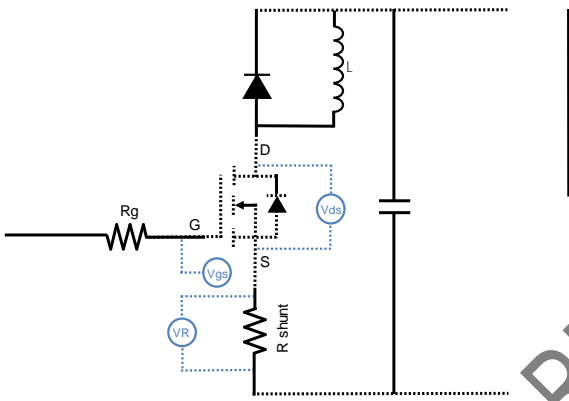

Figure C. Resistive Switching Test Circuit & Waveform

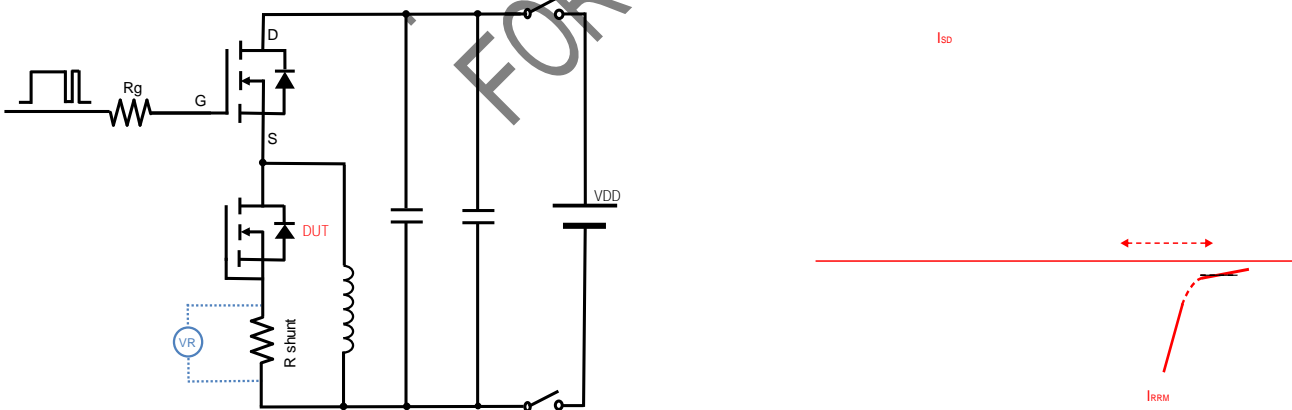
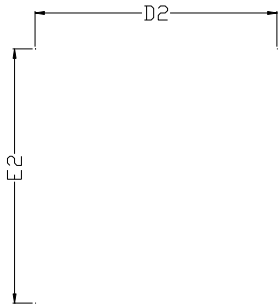

Figure D. Diode Recovery Test Circuit & Waveform



PDFN5060-8L-D-0.95MM Package information



Top View

Bottom View

Side View

SYMBOL	MILLIMETER		
	MIN	NOM	MAX
D	5.15	5.35	5.55
E	5.95	6.05	6.15
A	0.85	0.95	1.00
A1	0.203 BSC		
A2	0.08		
D1	4.25	4.35	4.45
E1	3.525	3.625	3.725
D2	5.20		
E2	5.55		
L1	0.4		

Note:

1. Controlling dimension: in millimeters.
2. General tolerance: $\pm 0.10\text{mm}$.
3. The pad layout is for reference purposes only.

NOT RECOMMEND FOR NEW DESIGN



YJG220G06AR

RECOMMEND
YJG210G06AR
FOR NEW DESIGN

Disclaimer

The information presented in this document is for reference only. Yangzhou Yangjie Electronic Technology Co., Ltd. reserves t