

—

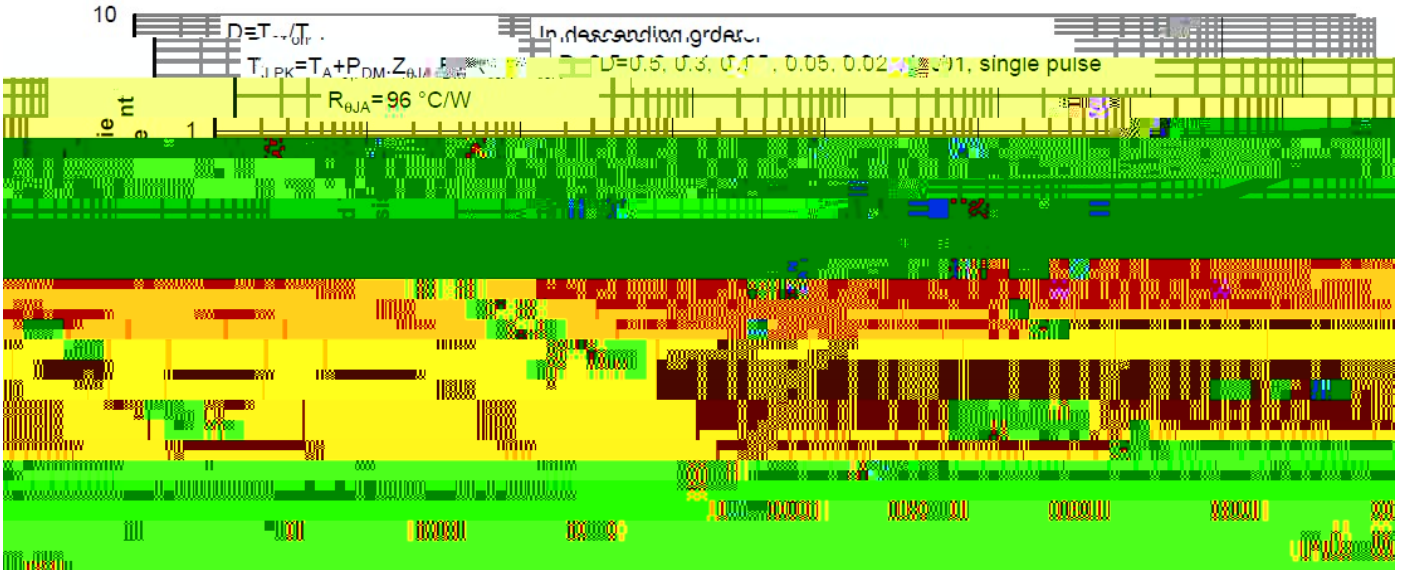

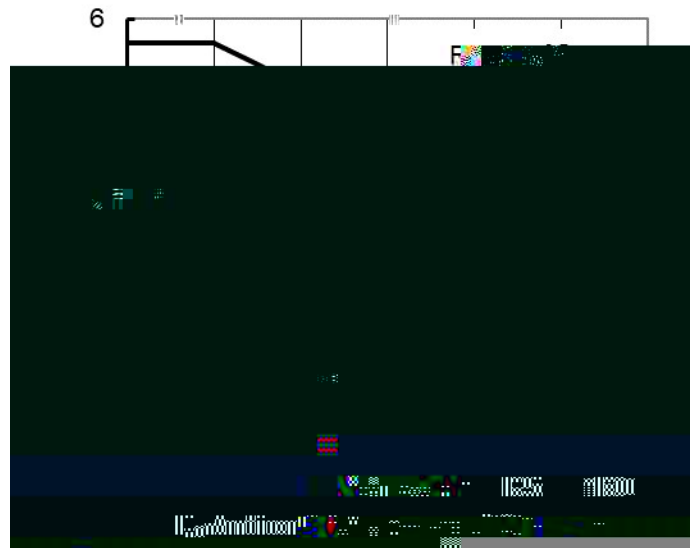

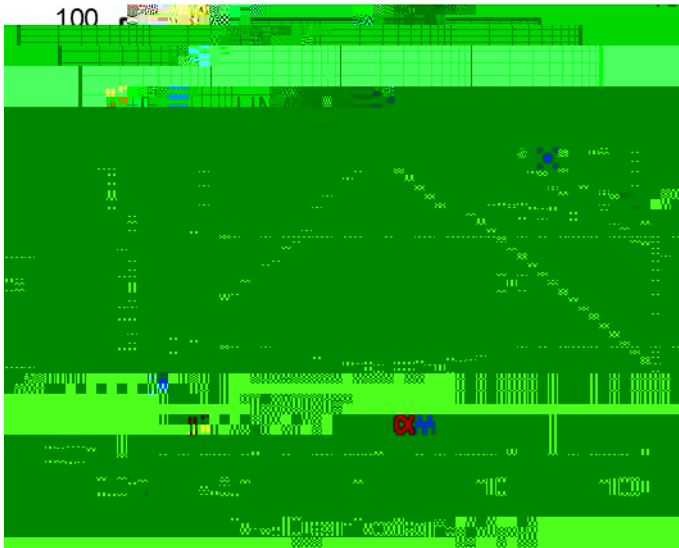





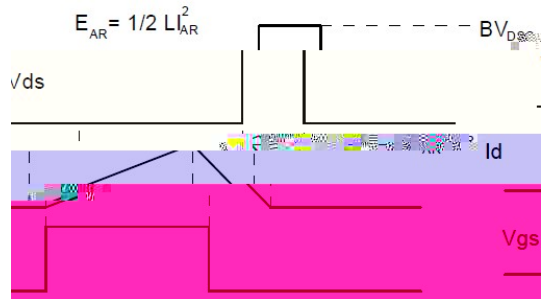
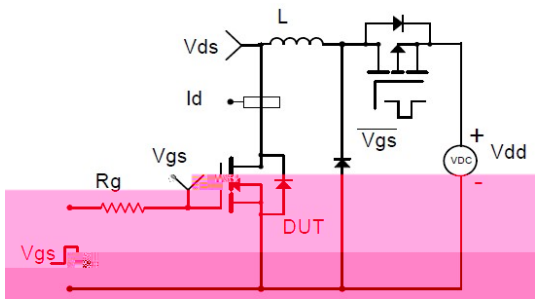
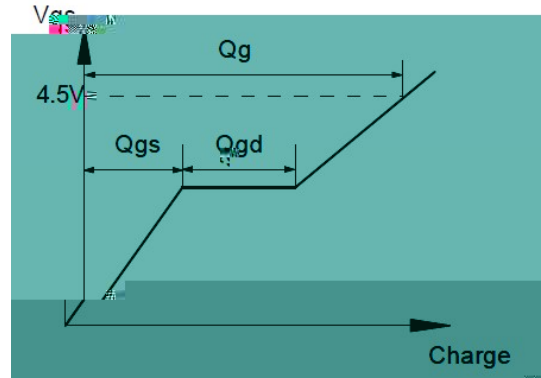
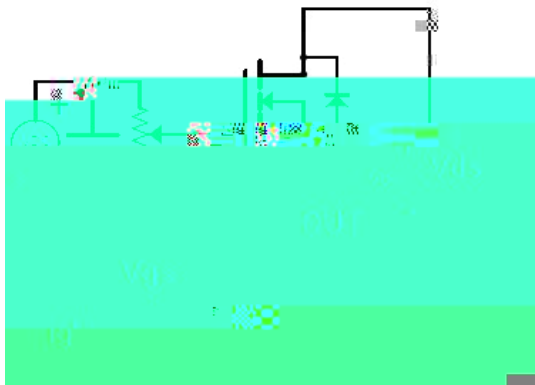
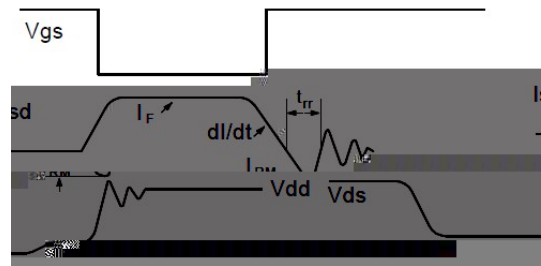
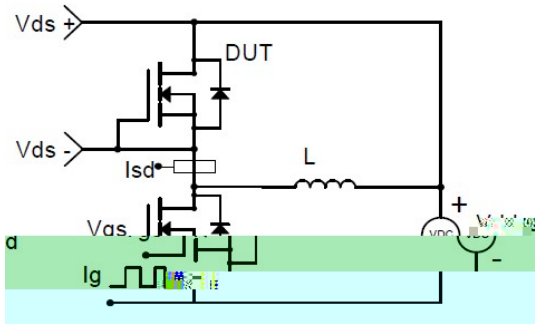
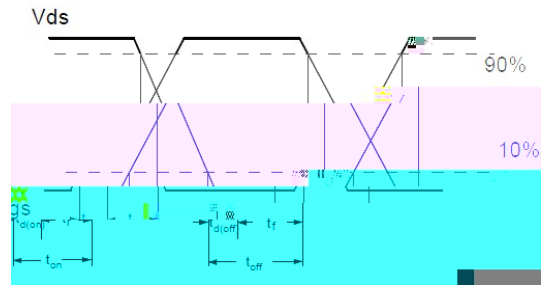
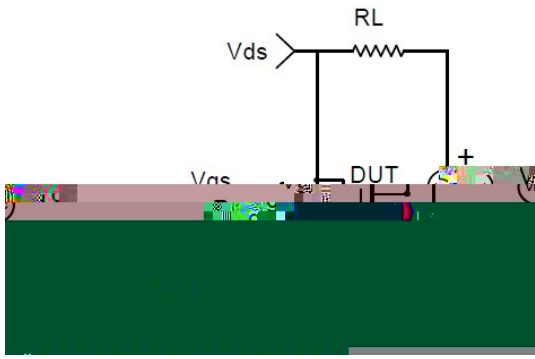

$$E_{AR} = 1/2 L I_{AR}^2$$



